

# Product Information Sheet

## Support Leg

### CCLEG2

- Mark all holes / centre line positions as accurately as possible.
- Take care not to damage hardware or chip powder coatings.

1. Mark off the vertical centre line of the support onto the front edge of the partition, ideally this should be within 250mm from the front edge
2. Loosen the retaining screw in the Leg Shroud and lift up the Shroud to access the adjuster mechanism adjust the block up into the support as far as it will allow.
3. Offer up the support to the partition and mark out the hole position on the centre line.
4. Drill through using a  $\varnothing 9.5\text{mm}$  drill.
5. Fix support to partition using the M6 T Nuts and M6 x 20 Althread.
6. The partition can now be mounted to the wall, ensure that the front edge is supported by the use of packing pieces.
7. Once the partition is secure, the support block can be adjusted to floor level taking full support of the partition.
8. Using a  $\varnothing 5.50\text{mm}$  masonry drill, drill through the block following the angle to a depth of 50mm
9. Fit red wall plugs and secure the foot to the floor using the No.8 x 2" Woodscrews.
10. The shroud can now be lowered to the floor and secured using the retaining screw.

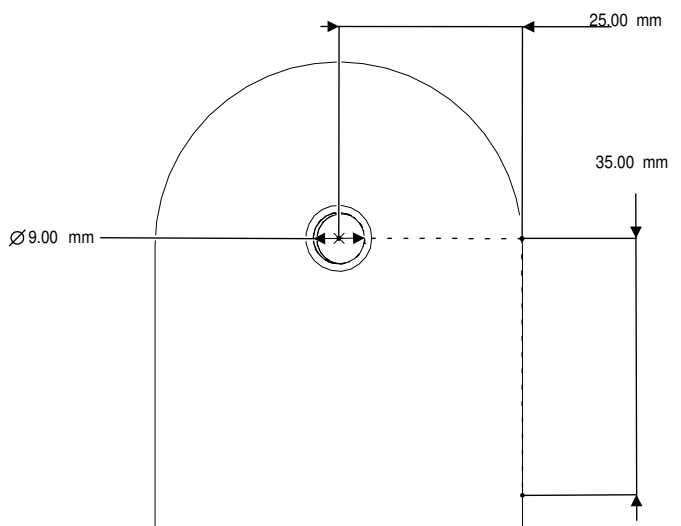
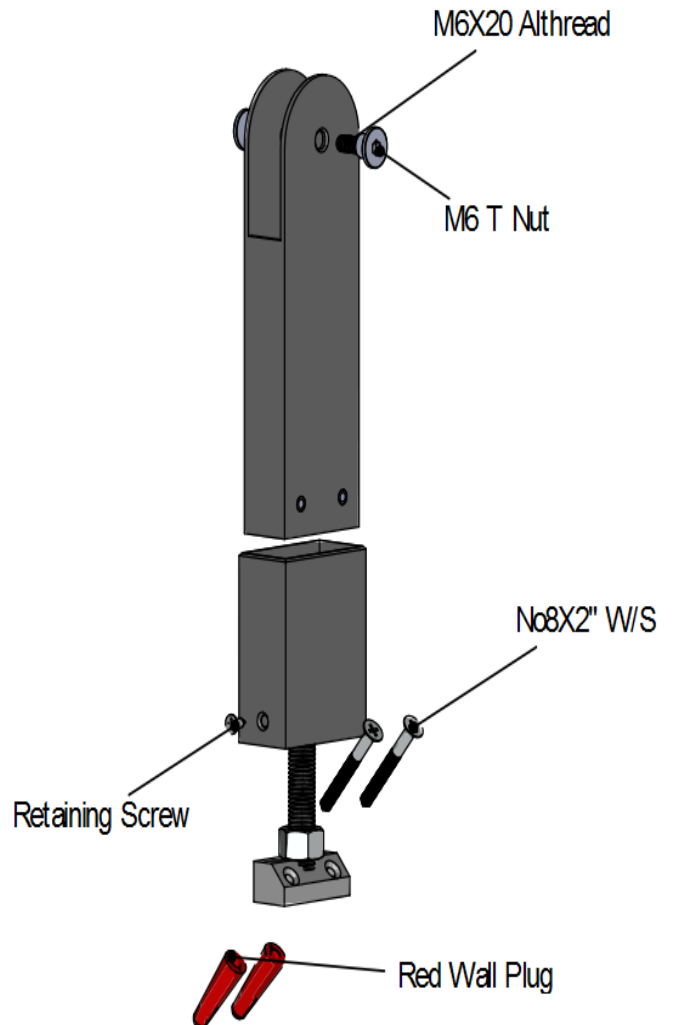

**cobtec**  
cubicle hardware

Unit 15, Dabble Duck Ind. Est.  
Shildon  
Co. Durham  
UK  
DL4 2QN

Phone: +44 (0)1388 770580 Fax: +44 (0)1388 778491

E-mail: [cobtec@bignall.co.uk](mailto:cobtec@bignall.co.uk)

REF: CCLEG2 Iss. 3