

Product Information Sheet

Hinge Assembly

HI 4/1 HINGE

- The HI4/1 Hinges are face fixed to the back of the facia and the edge of the door
- The edge of the door needs to be pre-drilled to the dimensions shown
- To ensure trouble free operation of the hinges it is important to be accurate and as vertical as possible to prevent binding of risers.
- When dismantling the hinge remove the M5x10 Screw from the hinge pin and pull apart.
- Align hinges to door and partition and secure with screws provided.
- When fitting ensure the hinge pin is pointing downward.
- Lift door into place and test for smooth operation. Hinges are supplied in the 'Door Open' position.
- When satisfied with operation replace M5x10 Machine Screw to hinge pin.

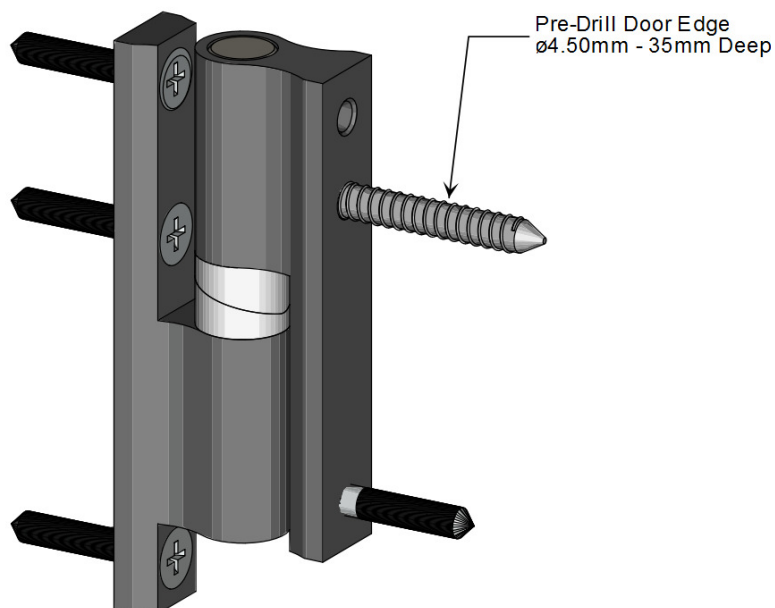
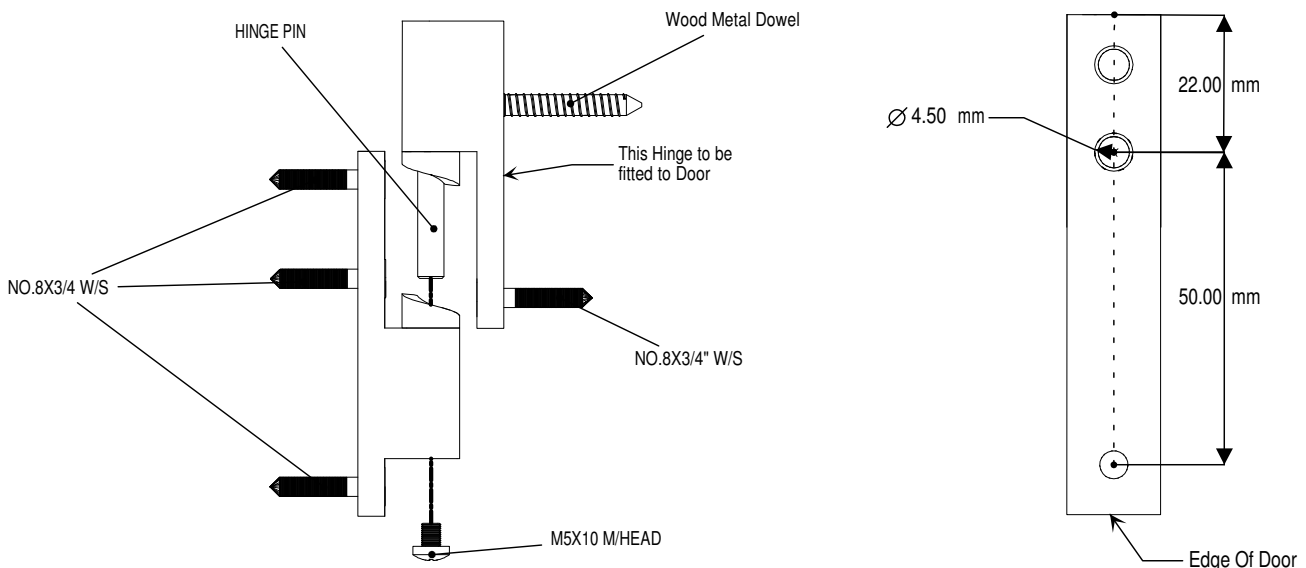

cobtec
cubicle hardware

Unit 15, Dabble Duck Ind. Est.
Shildon
Co. Durham
UK
DL4 2QN