

# cobtec

## cubicle hardware

Unit 8, All Saints Ind Est, Redworth Road, Shildon, Co. Durham, DL4 2RD, ENGLAND  
Tel: +44 (0) 1388 775584 Fax: +44 (0) 1388 778893 Email Post@bignall.co.uk Website: <http://www.bignall.co.uk>

### PRODUCT SPECIFICATION FOR: WM3/4-18

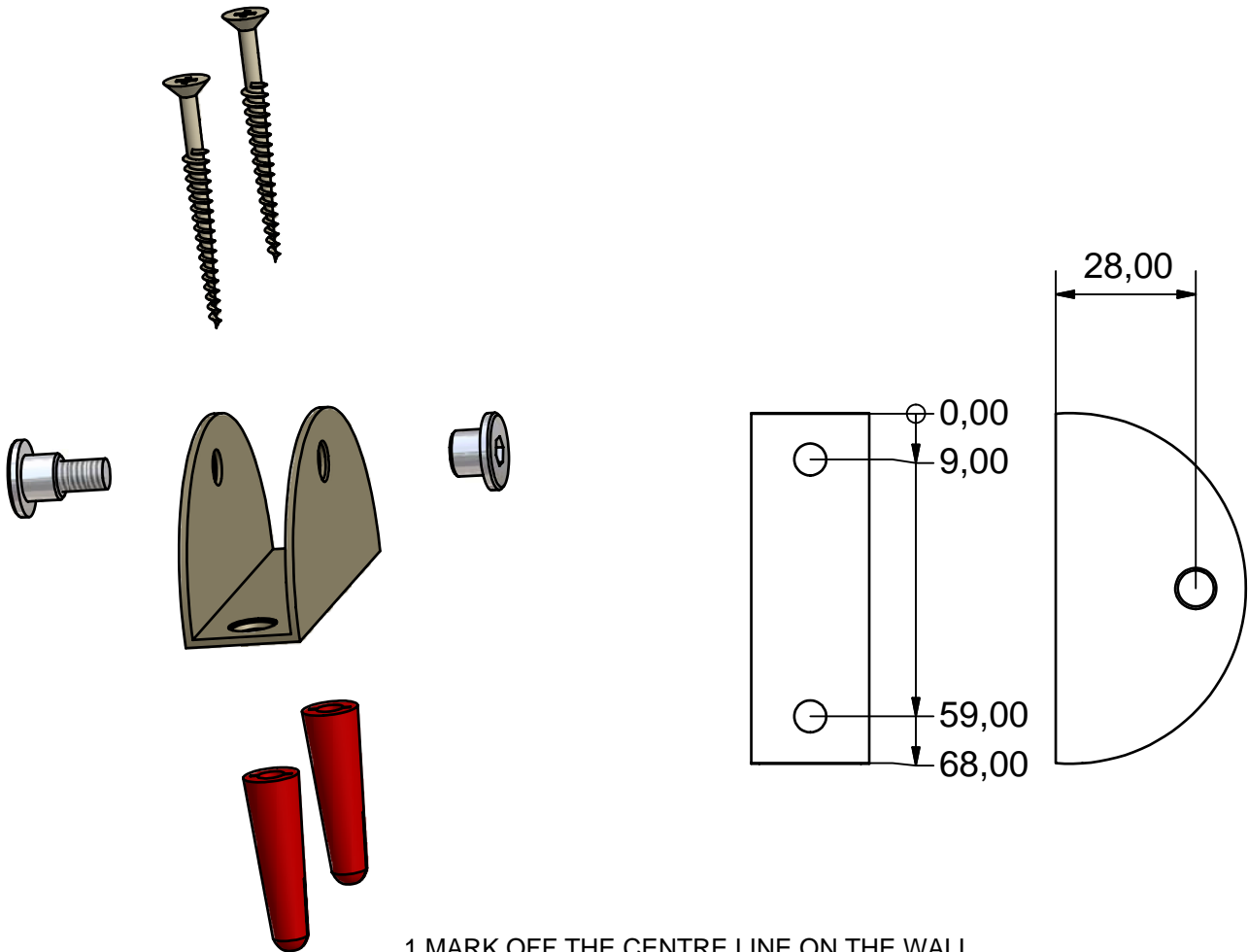

- 1 MARK OFF THE CENTRE LINE ON THE WALL.
- 2 POSITION THE BRACKETS ON THE CENTRE LINE.
- 3 MARK THE TWO HOLES PER BRACKET.
- 4 DRILL THE HOLES AT  $\varnothing 5.5$  MINIMUM DEPTH 50 MM.
- 5 SECURE THE BRACKETS USING THE WALL PLUGS AND SCREWS PROVIDED.
- 6 REPEAT STEPS ONE TO THREE ON THE FASCIA PANEL.
- 7 PILOT DRILL THE HOLES TAKING CARE NOT TO BREAK THROUGH THE FASCIA.
- 8 SECURE THE BRACKETS TO THE FASCIA WITH THE SCREWS PROVIDED.
- 9 POSITION THE PARTITION IN THE BRACKETS.
- 10 DRILL THROUGH THE BRACKETS USING A  $\varnothing 9.50$  MM DRILL.
- 11 SECURE THE PANEL TO THE BRACKETS USING THE T NUTS AND ALL THREAD PROVIDED.